

## **PHY-23.1 Test Information**

This document discusses DAQTron's implementation of the CableLabs® PHY 23.1 ATP titled "*Symbol Rate Change Test*" for cable modem testing. This script was written based on the procedures outlined in TP-RFI-ATPv1.1-I02-010919 and the CableLabs TEP release 11-07-2001.

### **Overview**

This test measures the capability of the DOCSIS system to continue to operate normally while the symbol rate is changed. For this test to succeed, the CMTS must manage the symbol rate change such that outstanding grants are completed before the symbol rate change is communicated to the CM. The CM must queue up packets until they are sent to the CMTS.

A packet source and a packet receiver are used to generate and receive upstream traffic from the CM to the CMTS. The packets are counted. The symbol rate is changed by one symbol rate size, in either direction while the packets are being sent. There should be no packets lost as a result of the symbol rate change.

### **Known Issues: ATP Deviations, Assumptions and Caveats**

The following list contains all the current issues and ATP deviations. The issues can be with the ATP, 3<sup>rd</sup> Party Hardware, or DAQTron's implementation.

- ATP does not pass traffic downstream. This was corrected in the TEP. The downstream packets are useful to help determine if the CM reregisters. The script uses both upstream and downstream traffic in its analysis.
- ATP does not perform a baseline test. The purpose of the test is to verify that packets are dropped because of a change in symbol rate. Before testing for that, it needs to be verified that packets aren't dropped during steady-state conditions. This was corrected in the TEP an implemented in DAQTron's script. If desired, the baseline test can be skipped by setting the number of baseline packets to 0.
- The ATP calls for 100 packets per second (pps) transfer rate. The TEP modifies this to 20 pps. DAQTron has verified with CableLabs testers that 20 pps is used in testing. The DAQTron script defaults to 20 pps but it is configurable.
- The ATP calls for 6000 packets, enough to equal 1 minute per test case. The TEP specifies traffic for 6 minutes. It is DAQTron's experience that 1 to 1.5 minutes per test case is sufficient to verify compliance. This is configurable in the DAQTron script by specifying both the packet rate (pps) and the total number of packets. The default values are 20 packets/sec and 1500 packets.
- The ATP does not specify how long to wait after starting the transmission before changing the symbol rate. The TEP requires the symbol rate be changed before the end of the first minute but at least after 30 seconds. This is a configurable parameter in the DAQTron script and defaults to 30 seconds.
- The ATP and the TEP specify 64 byte packets. This is a configurable parameter in the DAQTron script and defaults to 64 bytes.
- The ATP considers failure to be loss of 1 packet. The TEP considers failure to be failure to be dropping more packets that the equivalent of half a second (at 20 pps this equals 10

packets). DAQTron's script reports both the number of packets dropped and the percentage of packets dropped. Either one or both can be used as PASS/FAIL criteria.

- As an additional check, the DAQTron script monitors the CmtsCmStatus throughout the course of the packet transmission. The ATP and the TEP do not include this analysis.

## ***Hardware Requirements and Setup***

The following equipment is required:

- 1.1 CMTS
- Packet Generator
- Servers (DHCP, TFTP, ToD)
- Test Controller PC
- Basic Cable Plant Connectivity (no switch or attenuation control)

### **Hardware diagram**

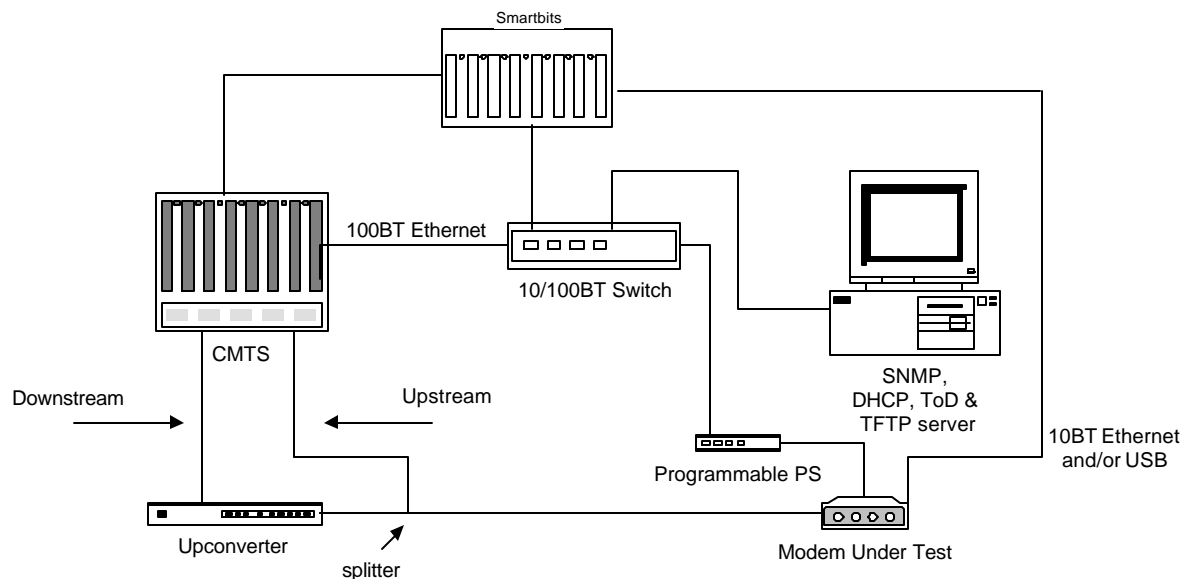

## ***Software Requirements and Setup***

### **Configuration File Details**

#### **Basic\_1\_1.cfg**

Network Access Control Object(3) = 1  
Maximum Number of CPEs(18) = 16  
Upstream Service Flow Encoding(24)  
Service Flow Reference(24.1) = 1  
Quality of Service Parameter Set Type(24.6) = 7  
Service Flow Scheduling Type(24.15) = 2  
Downstream Service Flow Encoding(25)  
Service Flow Reference(25.1) = 5

Quality of Service Parameter Set Type(25.6) = 7  
Privacy Enable(29) = 0

## Environment File Details

The environment file is broken into 2 sections: Basic and Advanced. The Basic section is used to change parameters that can vary from run-to-run (which test points to include). The Advanced section contains parameters that setup how the test is performed and are typically only modified initially. Each section is discussed in more detail below.

### BASIC:

The parameters in the Basic section control which test points to perform. The test points in PHY-23.1 are the various symbol rate changes (or channel width changes). There are 8 possible changes in the ATP. To perform a particular test point, set its value to TRUE. Otherwise set it to FALSE. The 8 test points are fixed and no new test points (i.e. 3200 to 800) can be added. An example of the Basic section is:

```
[Basic]
3200 To 1600=TRUE
1600 To 800=TRUE
800 To 400=TRUE
400 To 200=TRUE
200 To 400=TRUE
400 To 800=TRUE
800 To 1600=TRUE
1600 To 3200=TRUE
```

### ADVANCED:

The parameters in the Advanced section control how each test point is performed. See the Known Issues section of this document for a more detailed discussion of several of the parameters. An example section with comments is:

```
[Advanced]
Number of Test Packets = 1500 /*** Number of packets to send during symbol rate change test
Packet Rate = 20 /*** Packets per second
Packet Length = 64 /*** Bytes (including 4-byte CRC)
Change Delay = 30 /*** Number of seconds to wait before changing the symbol rate (Procedures 1 & 2)
Baseline Packets = 100 /*** Number of packets to use in the baseline test (Procedures 1 & 2)
Baseline Minimum = 100 /*** Minimum number of received packets to continue this test (Procedures 1 & 2)
CM Online Timeout = 30 /*** Maximum time (seconds) to wait for modem to come online
US Modulation = 16-QAM
```

## Hardware.ini File Additions

NONE

## Limit Files

The PHY-23.1 limit file provides a way to customize the analysis of the results for the purpose of calculating PASS/FAIL. The file contains tags that are associated with measurements performed by the script. In order to skip analysis of one particular tag, comment out the appropriate line in the limits file with the “/\*\*\*” character sequence. Each tag will be discussed in detail below. An example PHY-23.1 limits file is provided at the end of this section.

- CmtsCmStatus: This measurement involves polling the CM's status as reported by the CMTS throughout the course of the packet transmission. It reports the "worst-case" status achieved during that time frame. Worst-case is determined by the MIB value returned by the CMTS, with Registration Complete being the best-case and Other being the worst-case. The resulting worst-case status is written in C0. Possible values for status are:
  - n/a
  - Other
  - Ranging
  - Ranging Aborted
  - Ranging Complete
  - DHCP
  - Registration Complete
  - Access Denied
- PacketTest: This measurement stores the number of transmitted packets as well as the number of packets dropped. This same tag is used for both upstream and downstream traffic. The measurements/values associated with this tag are:
  - Actual Transmitted Packets – Stored in C1
  - Number of Dropped Packets – Stored in C2
  - Desired number of Transmitted Packets – Store in C3
- PacketTestPercent: This measurement stores the percent packets that were received relative to the actual number transmitted. The results are stored in C0. This same tag is used for both upstream and downstream traffic.
- SkippedTest: The tag is posted every time a test point that was configured to be tested is skipped. The test point is skipped because either the modem never came online initially or it failed the baseline test. The tag is not posted if the operator requested that a particular test point be skipped. This post always puts "Skipped" into C0.
- BaselineTest: This tag posts the results of the baseline test. This measurement stores the number of transmitted packets as well as the number of packets dropped. This same tag is used for both upstream and downstream traffic. The measurements/values associated with this tag are:
  - Actual Transmitted Packets – Stored in C1
  - Number of Dropped Packets – Stored in C2
  - Desired number of Transmitted Packets – Store in C3
- TotalPacketPercent: This measurement posts the overall average percent packets transmitted (and received). The average is determined from the result of the packet tests of all test points. The average is posted in C0.

### **PHY-23.1.lmt**

CmtsCmStatus,C0%T,EQ,Registration Complete  
 PacketTest,C1%P,EQ,C3||C2%R,LE,3||.AND.  
 PacketTestPercent,C0%R,GE,95  
 SkippedTest,C0%T,NE,Skipped  
 BaselineTest,C1%P,EQ,C3||C2%R,LE,0||.AND.  
 TotalPacketPercent,C0%R,GE,95

## **Physical Layer Configurations**

The following Standard PHY Configurations have been defined by DOCSIS in order to promote repeatability of tests. Unless otherwise specified in the test procedures, the PHY configurations are only recommendations.

**Standard PHY Config 1**

Symbol Rate = 1,280 ksym/sec

Modulation Type = QPSK

**Standard PHY Config 2**

Symbol Rate = 160 ksym/sec

Modulation Type = QPSK

**Standard PHY Config 3**

Symbol Rate = 2,560 ksym/sec

Modulation Type = 16QAM

## ***DAQTron's Test Procedure***

1. Set the symbol rate to the first symbol rate defined in the test point.
2. Verify that the modem is online (If not skip the rest of this test point)
3. If number of baseline packets to transmit > 0, perform the baseline test. (Skip rest of test point if too many packets are dropped)
4. Start the packet generator using the configured values for number of packets, packet length, and packets per second.
5. Begin monitoring CmtsCmStatus
6. After waiting the configured number of seconds, change the symbol rate on the CMTS to the second symbol rate defined in the test point.
7. Wait for packet transmission to complete.
8. Stop monitoring CmtsCmStatus, post worst-case
9. Post packet transmission results.
10. Repeat steps 1-9 for all test points.
11. Post average packet reception for all test cases.

## ***Miscellaneous Information***

### **Expected Test Time**

The test time varies according to how it is configured. Using DAQTron's default configuration the average test time is approximately 3 minutes per test point with a total of 8 test points in the ATP. The assumes the following configuration:

- Number of Test Packets = 1500
- Packet Rate = 20 /\*\*\* packets per second
- Baseline Packets = 100

### **MIB Objects**

### **PICS Covered**

PICS Item	Feature
CMTSMaMsg.1	The guard time MUST be greater than or equal to the duration of five symbols plus the maximum timing error
CMPPhTx.11	The upstream modulator MUST provide QPSK at 160 ksym/sec.
CMPPhTx.12	The upstream modulator MUST provide QPSK at 320 ksym/sec
CMPPhTx.13	The upstream modulator MUST provide QPSK at 640 ksym/sec
CMPPhTx.14	The upstream modulator MUST provide QPSK at 1,280 ksym/sec
CMPPhTx.15	The upstream modulator MUST provide QPSK at 2,560 ksym/sec

CMPHx.16	The upstream modulator MUST provide 16QAM at 160 ksym/sec
CMPHx.17	The upstream modulator MUST provide 16QAM at 320 ksym/sec
CMPHx.18	The upstream modulator MUST provide 16QAM at 640 ksym/sec
CMPHx.19	The upstream modulator MUST provide 16QAM at 1,280 ksym/sec
CMPHx.20	The upstream modulator MUST provide 16QAM at 2,560 ksym/sec
CMPHx.21	All CMs using that upstream channel MUST use the defined symbol rate for upstream transmissions
CMPHx.74	For Symbol Rate changes the CM MUST be able to transmit consecutive bursts as long as the CMTS allocates at least 96 symbols in between the last symbol center of one burst and the first symbol center of the following burst

## Packet Formats

The packets used in this test are standard IP packets of configurable length (defaults to 64 bytes).